

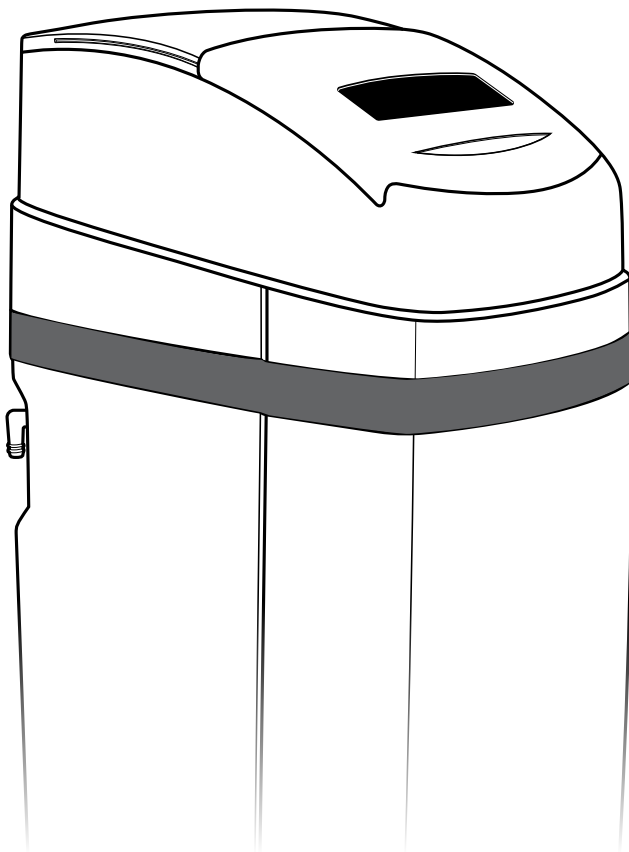

TAN-E1

*TAN-E1 Automatic Domestic Tannin Reduction
System User Guide*



What's Inside

Puretec Customer Service	3
Installation Record	4
Before Installation.....	5
Specifications	7
Exploded Diagram.....	8
Diagram Identification	9
Dimensions.....	10
Installation Procedure	11
Programming.....	15
Start-Up	17
Replenishment of Salt Supply	18
Type of Salt to Use.....	18
Media Replacement.....	18
Maintenance.....	18
Replace the Backup Battery.....	19
Bypass Valve Operation - optional accessory	20
Troubleshooting Guide	21
Warranty.....	25



WaterMark

WMTS103

Licence No. WM 74593

Pro-Switch Pty Ltd



CAUTION

**DO NOT OVERTIGHTEN.
DO NOT USE
LIQUID SEALANTS.**





WARNING

THIS PRODUCT CONTAINS A BUTTON BATTERY

If swallowed, a lithium button battery can cause severe or fatal injuries within 2 hours.
Keep batteries out of reach of children.
If you suspect your child has swallowed or inserted a button battery, immediately call the 24-hour Poisons Information Centre 13 11 26 (in Australia).

Puretec Customer Service

Thank you for purchasing a Puretec TAN-E1 Automatic Tannin Reduction System. Your system is a proven performer manufactured from only quality materials and components. It will give years of reliability and trouble free operation if maintained properly.

This user guide is designed for Puretec TAN-E1 Water Treatment Systems. Be careful to ensure the information and illustration is applicable to your particular unit.

Caution: Do not use with water that is microbiologically unsafe or without adequate disinfection before or after the system.

The systems are designed for bore water/ river water/ rainwater but can be used in other situations. For other types of water supply, please contact your local Puretec dealer.

Puretec Tannin Reduction Systems are designed to run economically for many years, dependent on the initial installation and periodic maintenance.

Flush system for 5 minutes or more, after any period of non-use, more than 2 weeks.

Installation Note: A water filter system/tap, like any product, has a limited lifespan and if not replaced, will eventually fail. Failure can happen early due to unforeseen circumstances. To avoid possible property damage, this product should be regularly examined for leakage and/or deterioration and replaced when necessary. We strongly recommend that a drain pan, plumbed to an appropriate drain or outfitted with a leak detector, be used in those applications where any leakage could cause property damage. We also strongly recommend that the water supply be turned off, upstream to the water filter system/tap, if no one is home for an extended period of time.

INSTALLATION SHOULD BE COMPLETED BY QUALIFIED TRADESPEOPLE. FAULTY OPERATION DUE TO UNQUALIFIED PERSONS WILL RESULT IN VOIDED WARRANTY COVERAGE.

WARNING: CHLORINE MUST BE ABSENT FROM THE WATER - CHLORINE PERMANENTLY DAMAGES THE TANNIN REDUCTION RESIN & IS NOT COVERED UNDER WARRANTY. IF CHLORINE IS PRESENT, A CARBON PRE-FILTER MUST BE INSTALLED PRIOR TO THE TANNIN REDUCTION SYSTEM SUCH AS THE WH2 OR CFS SERIES. PLEASE REFER TO PURETEC FOR A SPECIFIC RECOMMENDATION. A CARBON PRE-FILTER PROTECTS AGAINST CHLORINE SPIKES & PROLONGS THE RESIN LIFE.

Installation Record

For future reference, fill in the following data

Product Information	
Model Number:	
Serial / Batch Number:	
Purchased from:	
Date of Installation:	
Installer / Plumber Details:	

Water Analysis Information	
Hardness:	_____ ppm / mg/L
Iron:	_____ ppm / mg/L
Manganese:	_____ ppm / mg/L
pH:	_____
TDS (Total Dissolved Salts):	_____ ppm / mg/L
Conductivity:	_____ EC / uS/cm
Chloride:	_____ ppm / mg/L
Sodium:	_____ ppm / mg/L
NOM (Natural Organic Matter):	_____ ppm / mg/L

Before Installation

Professional Installation Required

- Installation requires shutting water off to home, cutting home water supply pipe and using a welding torch to add piping and fittings. Specialised tools and skills are required, this must be completed by a qualified tradesperson.

Make Sure Your Water Has Been Thoroughly Tested

- An analysis of your water should be made prior to the selection of your water treatment system. Your dealer will generally perform this service for you, and may send a sample to the factory for analysis and recommendations. Enter your analysis information on page 4 for your permanent record.

Install Equipment Correctly

Select the location of your tannin reduction system with care. Various conditions which contribute to proper location are as follows:

- Install as close as possible to a drain.
- Install in correct relationship to other water treatment equipment. Contact Puretec for assistance.
- Install the tannin reduction system in the supply line BEFORE the water heater. Temperatures above 43°C will damage the system and void the warranty.
- DO NOT install the tannin reduction system in a location where freezing temperatures occur. Freezing may cause permanent damage and will also void the warranty.
- DO NOT install where water hammer conditions may occur without installing an arrestor.
- Allow sufficient space around the installation for easy servicing. Provide a non-switched 240V power source for the control valve.
- Protect from pressure vacuum with a suitable vacuum breaker.
- Where line pressure exceeds 500 kPa, an approved pressure limiting device must be installed to comply with Australian & New Zealand Plumbing Standards. (Ref. AS/NZS 3500.1:2021, Clause 3.3.4).
- For point of entry installations an approved backflow prevention device must be installed.

Things to Remember While Planning Your Installation:

- All installation procedures **MUST** conform to local plumbing codes.
- If lawn sprinklers, a swimming pool, or geothermal heating/cooling or water for other devices/activities are to be treated by the tannin reduction system, a larger model **MUST** be selected to accommodate the higher flow rate plus the backwashing requirements of the tannin reduction system. Contact Puretec for assistance.



**WARNING - THESE STEPS ARE CRITICAL FOR THE CORRECT
INSTALLATION OF YOUR WATER TREATMENT SYSTEM.**

- The control valve, fittings and/or bypass are designed to accommodate minor plumbing misalignment but are not designed to support the weight of a system or the plumbing.
- The unit must be installed on a surface that is firm, level, horizontal in both directions and fully supports the entire base of the system. The system can weigh a considerable amount when full and the base must be suitable to support this weight.
- Do not use petroleum jelly, oils, other hydrocarbon lubricants or spray silicone anywhere. A silicon lubricant may be used on the black o-rings but it is not necessary.
- Do not use pipe dope or other sealants on threads. Thread seal tape is the preferred sealant but is not necessary on the nut connection or caps because of o-ring seals.
- All plumbing should be done in accordance with local plumbing codes. The pipe size for the drain line should be a minimum of 5/8".
- Avoid getting primer and solvent cement on filter system.
- Install grounding strap on metal pipes if required.
- Ensure the system is protected against high pressure and extreme temperatures.
- Chlorine must be absent from the water - chlorine permanently damages the tannin reduction resin & is not covered under warranty. If chlorine is present, a carbon pre-filter must be installed prior to the tannin reduction system such as the WH2 or CFS Series. Please refer to Puretec for a specific recommendation. A carbon pre-filter protects against chlorine spikes & prolongs the resin life.
- If pressure exceeds 500 kPa an approved pressure limiting device needs to be fitted.

Specifications

Operating Pressure Min/Max:	138 - 862* kPa
pH Min/Max:	6.0 - 8.0
TDS:	<300 ppm
Total Suspended Matter (TOC):	<25 ppm
Free Chlorine:	0 ppm
Operating Temperature Min/Max:	0 - 43 °C (protect from freezing)
Electrical Connection:	240V / 50 Hz
Inlet/Outlet Connection:	1" Male BSPT
Drain Connection:	5/8"
Overflow Connection:	5/8"
Flow Rate:	40 Lpm
Capacity - River water high in organics (TOC <25ppm):	2,700 L
Capacity - River water low in organics (TOC <5 ppm):	8,750 L
Capacity - Rainwater (TOC <2ppm):	21,800 L
Width (mm) (W):	350
Height (mm) (H):	1125
Depth (mm) (D):	490
Dry Weight (kg):	31 kg.

* Where line pressure exceeds 500 kPa, an approved pressure limiting device must be installed to comply with Australian & New Zealand Plumbing Standards. (Ref. AS/NZS 3500.1:2021, Clause 3.3.4).

Exploded Diagram

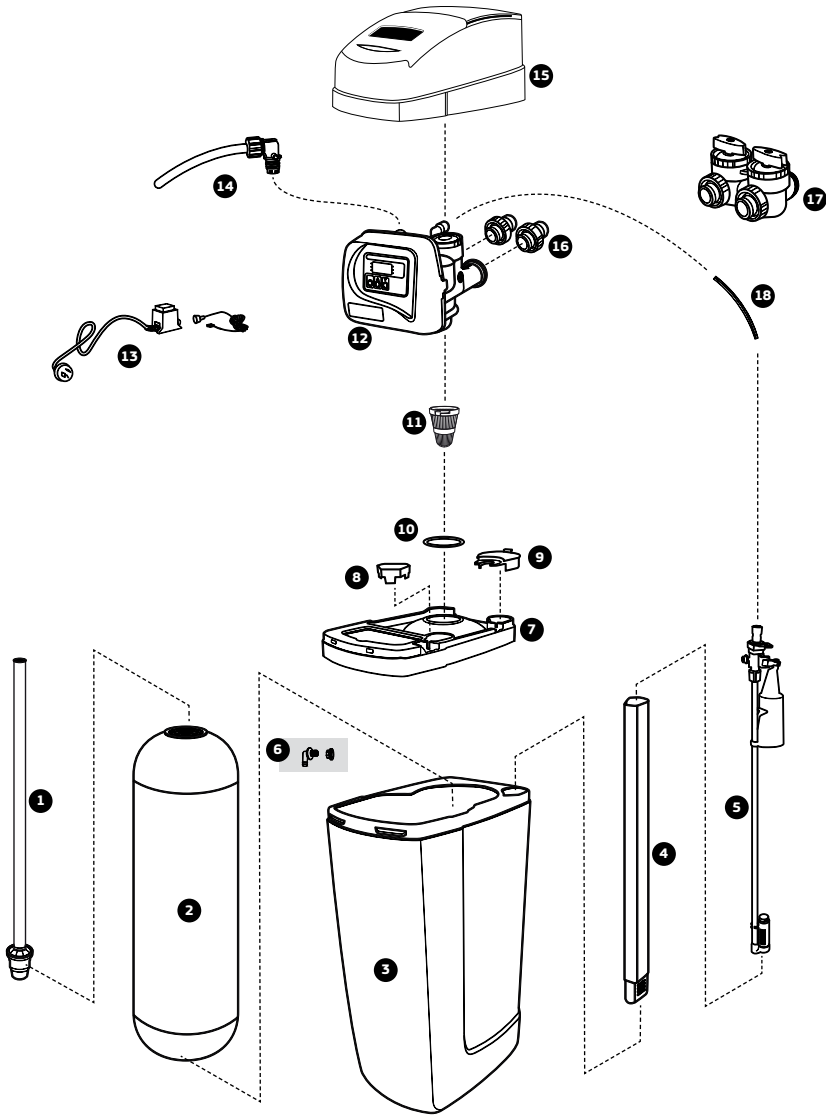

Parts Identification

Item	Part no	Description
1	WTD2030	Riser Pipe
2	-	Pressure Tank
3	WTB1035	Cabinet
4	-	Brine Well
5		Brine Pick-Up Assembly
6	WTB1035	2pc Overflow Kit
7	-	Brine Tank Lid
8	-	Brine Well Blank
9	-	Brine Well Lid
10	WTV3030	Pressure Tank Collar UV Shield

Item	Part no	Description
11	WTD1010	Top Screen
12	WTV4000	Automatic Timer Valve
13	WTV5135	Transformer Suits Auto Valves
14	-	Drain Tube Assembly
15	WTB2100	Cover
16	WTV5060	Plastic Fitting Kit
17	WTV5000	Bypass Assembly (purchased separately)
18	KTU6BK	Tubing High Pressure 3/8" Black

Diagram Identification

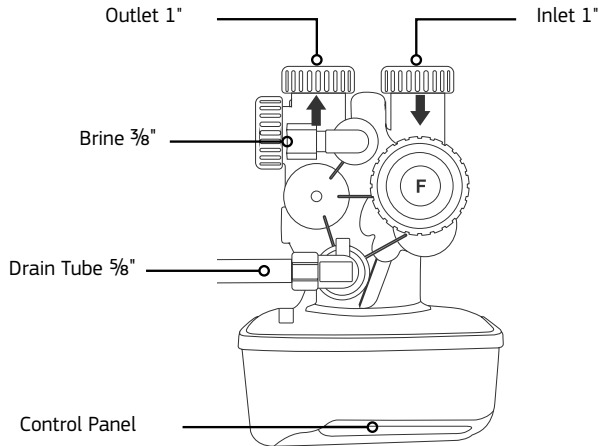

Dimensions

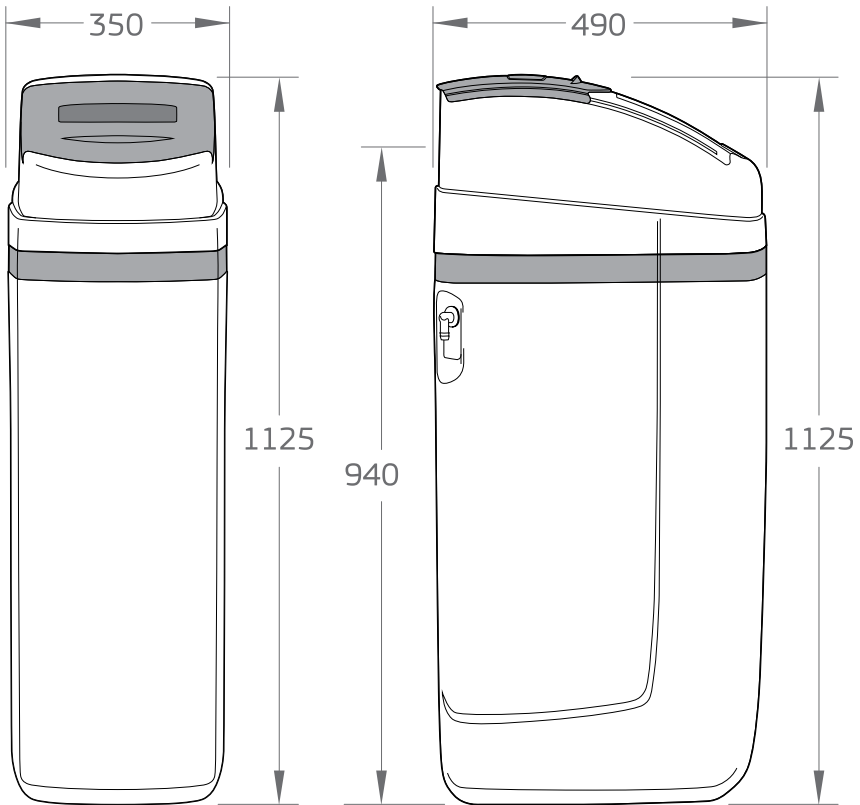

Installation Procedure

- 1** Unpack the equipment. Ensure all parts are present and have not been damaged in transport. You should have:

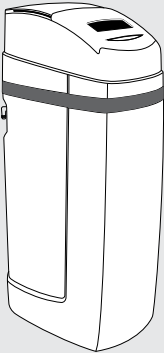

Tannin Reduction System

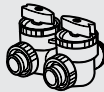

Bypass Assembly
(optional - purchased separately)



User Guide

- 2** Extra items required:



Bag of Salt (refer to page 16 for the type of salt to be used).



5/8" Additional tubing high pressure for drain and overflow (refer to page 14)

- 3** Ensure water has been tested, Input values into Table on page 4 and the analysis has been inspected by Puretec.

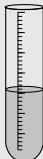

Water Analysis Information	
Hardness	— 3.50 — ppm / mg/L
Iron	— 0.5 — ppm / mg/L
Manganese	— 0.2 — ppm / mg/L
pH	— 7 —
TDS (Total Dissolved Solids)	— 2.75 — ppm / mg/L
Conductivity	— 400 — EC / uS/cm
Chloride	— 3.25 — ppm / mg/L
Sodium	— 16 — ppm / mg/L



Customer Service Helpline
1300 140 140 (AU) 0800 130 140 (NZ)



- 4** Position the Tannin Reduction System on a level surface. The unit must be installed on a surface or pad that is stable, level and able to support the entire base and wet weight of the unit.

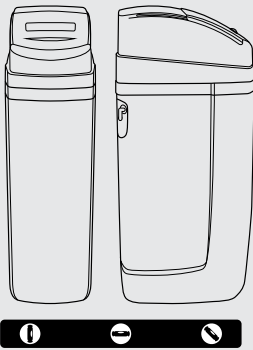

Environmental conditions:

Operating temperature: 0 - 43°C
(protect from freezing)

Water conditions

Temperature: 0-50°C

Pressure: 138 - 862* kPa

* Where line pressure exceeds 500 kPa, an approved pressure limiting device must be installed to comply with Australian & New Zealand Plumbing Standards. (Ref. AS/NZS 3500.1:2021, Clause 3.3.4).

- 5** Installing the Bypass (optional - purchased separately)

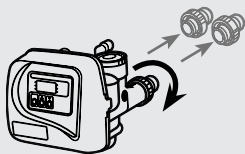

Uninstall the plastic fittings by turning the knob counter clockwise.

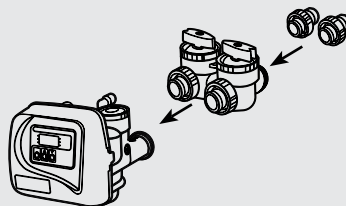

Connect the bypass assembly followed by the plastic fittings. Hand tighten the knobs, do not overtighten.

Refer to Bypass Valve Operation section.

6 Connecting the Tannin Reduction System

Connect the system to main plumbing. Do not solder brass adapters while they are inserted in the control module. Pipework must be aligned correctly with the inlet and outlet ports. Failure to do so may cause the misalignment of the cabinet components.

Apply plumbing tape to the nipple as required. Connect the pipe work to the valve, refer to page 9 for identification.

**FOLLOW LOCAL
PLUMBING CODES**

Note: Solder joints must be done prior to connecting to the valve fittings. Leave at least 6" between the fitting and solder joints when soldering pipes. Failure to do this could cause heat damage to the fittings.

This should be carried out by a qualified tradesman.

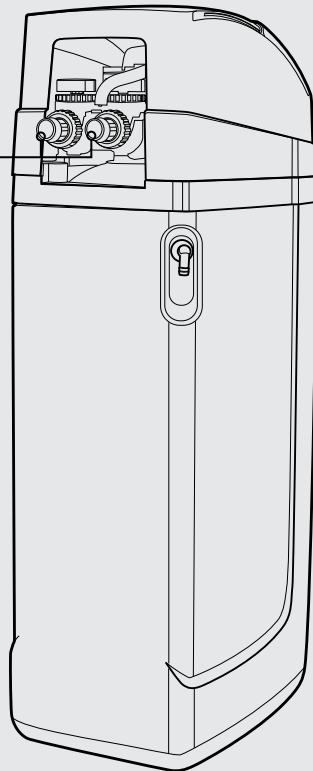

7 Connecting the Drain Line

Connect extra tube (tubing not supplied) onto the 5/8" drain line (pre-installed on the valve) from the valve to the drain. Ensure the drain line is not kinked. The line must not travel more than 2.4 m up and no more than 6 m long from the valve, otherwise increase the diameter of the drain line.

Connect drain and overflow to sewer or other approved salty water disposal point as approved by your local authority.

Ensure drain line has an adequate air gap of 2 times the pipe diameter or 25 mm, whichever is larger.

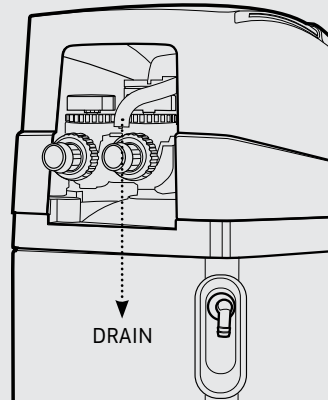

8 Connecting the Overflow

Connect tubing onto the 5/8" overflow fitting (tubing not supplied) and run the line to the drain. **Do not connect the overflow into the drain line**, as it must be a direct and separate line to the drain. Allow an air gap as per the drain line. Make sure the drain is not higher than the overflow.

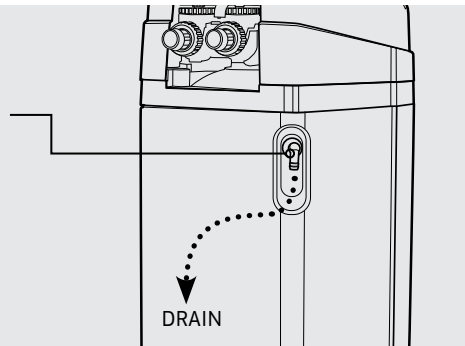

9 Programming

6.1 Plug into an uninterrupted electrical outlet.

Note: the system transformers are not weather resistant and should be adequately protected. All electrical connections must be connected accordingly to local codes.

6.2 Proceed to 'Programming' section.

Programming

General Operation

When the system is operating one of two displays will be shown. Pressing ▲ or ▼ button will alternate between the displays. One of the displays is always the current time of day (to the nearest hour).

The second display is the days remaining until the next regeneration. If the days remaining is equal to one, a generation will occur at the next present regeneration time. The user can scroll between displays as desired.

If the system has called for a regeneration that will occur at the present time of regeneration, the arrow will point to Regen.

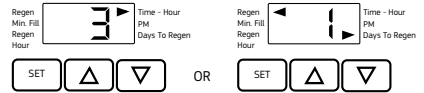

Set Time of Day

1. Press SET for 5 seconds
2. Current time: set HOUR by using the ▼ + ▲ button then press SET. Repeat for MINUTES.

After a power outage, the time of day will need to be reset.

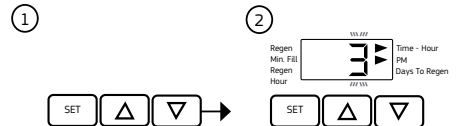

Other Settings - these have been factory set (only adjust if required)

1. From normal mode, press SET + ▲ buttons simultaneously for 5 seconds and release.
2. Regeneration Time: Set the clock to the hour the regeneration should occur by using the ▲ or ▼ buttons. Once the hour is chosen, press SET and repeat for MINUTES. Factory setting is 2 AM. Press SET to go to STEP 3.

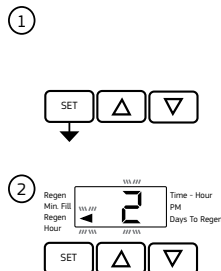

3. Days to Regen: This is factory set to 3 (3 days between regenerations). The allowable range is 1 to 99. Refer to "Regeneration" to set correct regen days. Press SET to exit Installer Displays and Settings.

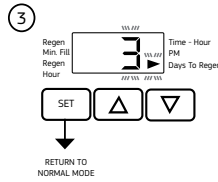

The system is factory set to regenerate at 2 AM. If there is a demand for water when the system is regenerating, untreated water will be used.

Use the below table to determine the recommended days between regeneration on the TAN40-E1 model, based on organic matter levels in your water.

River water high in organics (TOC <25 ppm)	3 days (2,700L capacity)
River water low in organics (TOC <5ppm)	10 days (8,750L capacity)
Rainwater (TOC <2ppm)	25 days (21,800L capacity)

Regeneration Mode

When the system begins to regenerate, the display will change to indicate the cycle of the regeneration process that is occurring and an arrow will also point to Regen. The system will run through the steps automatically and will reset itself to provide treated water when the regeneration is completed.



Manual Regeneration

Sometimes there is a need to regenerate the system sooner than when the system calls for it, usually referred to as a manual regeneration. There may be a period of heavy water usage because of guests or a heavy laundry day.

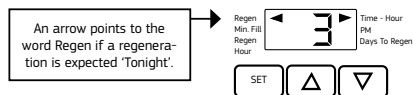

To initiate a manual regeneration at the preset delayed regeneration time, simultaneously press ▲ + ▼ buttons together and release. The arrow will point to the word Regen if a regeneration is expected 'tonight'. To cancel the regeneration simultaneously press ▲ + ▼ buttons and release.

To initiate a manual regeneration immediately, simultaneously press ▲ + ▼ buttons together for 3 seconds. The system will begin to regenerate immediately. The request cannot be cancelled.

Power Loss

Your Puretec electronic control valve maintains the time for up to 8 hours using the internal PCB battery if power is interrupted. Nonvolatile memory stores the stats & programming & are not affected by power outages. After 8 hours of backup use, replace the battery with a type 2032, 3-volt lithium coin cell battery. If the time flashes on & off after a power loss the time of day should be reset & the flat battery replaced.

In the unlikely event of a power loss during backwash, when power is restored, a dry-reset should be performed, followed by a manual backwash/regeneration if convenient.

Start-up

Now programming is completed (if required) you are ready to start the system.

1. Fill the brine tank with 'water softener' salt to approximately half full (salt not included). This will require approximately 50 kg (this is only required initially).
2. Add approximately 15 litres of water to the salt in the brine tank. This is only required for the initial setup.

Note: The water level will drop significantly after the first backwash, and may disappear below the salt line. This is normal and no extra water will be required.

3. Open the nearest tap downstream of the filter system (after the filter system).
4. Allow water to flow through the system slowly, and allow all air to escape out of the closest tap. Wait until the water is flowing out of the tap and then increase the flow slowly up to full flow. Allow to run for 5-10 minutes.
5. Close the opened tap and check for leaks.
6. Conduct a full manual regeneration.
7. Your system is ready for use.

Replenishment of Salt Supply

The salt storage capacity of the brine tank is approximately 50 kg. During each regeneration a small amount of salt is consumed, thus requiring periodic replenishment for a continuous supply of softened water (the frequency and salt dosage level is dependent on the regeneration schedule).

We recommend to maintain the salt level in the brine tank to 1/2 to 2/3 full (**DO NOT EXCEED 2/3 FULL**). The water level in the brine tank is maintained automatically and does not require manual intervention.

Note: The water level is usually below the salt level & therefore cannot be seen (this is not a problem).

Always replenish salt before the supply is exhausted.

Note: No extra water is required when topping up the salt level.

Type of Salt to Use

Any type of water softener salt may be used, but for best results, we recommend using coarse solar salt called "water softener salt" or alternatively "pool salt".

Media Replacement

Resin ordering code: **RMK-TAN40**.

Customer Service Helpline at **1300 140 140** (AU) and **0800 130 140** (NZ) for more details.

The nuts and caps are designed to be unscrewed or tightened by hand or with the special plastic wrench. If necessary pliers can be used to unscrew the nut or cap. Do not use a pipe wrench to tighten or loosen nuts or caps. Do not place screwdriver in slots on caps and/or tap with a hammer.

Maintenance

If microbial growth is suspected, sterilise the resin by passing 25-75 litres of diluted TankSafe™ through the media bed (1 litre of TankSafe™ per 74 litres of water).



⚠ WARNING

THIS PRODUCT CONTAINS A BUTTON BATTERY

If swallowed, a lithium button battery can cause severe or fatal injuries within 2 hours.

Keep batteries out of reach of children.

If you suspect your child has swallowed or inserted a button battery, immediately call the 24-hour Poisons Information Centre 13 11 26 (in Australia).

Replace the Backup Battery

The backup battery (CR2032 coin) keeps the time in case of a power outage. The battery should be replaced annually or after extended periods without power. Replacement batteries can also be ordered using code: BA-CR2032 through your local Puretec dealer.

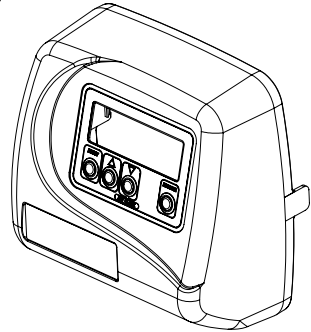

1. Turn off the power to the unit and remove the valve cover.
2. The coin battery (CR2032) is located in the top left hand corner of the PC Board.
3. Using a non conductive item (like the plastic end of a pen), poke the battery from underneath the battery mount and slide the old battery out.
4. Insert the new battery into the battery mount, ensuring it is fully seated and in the correct orientation (as shown).

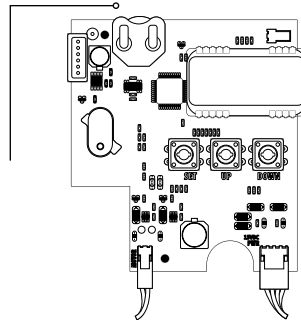

Correct battery orientation.

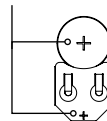

Battery is fully seated.

5. Replace the valve cover and switch the unit back on.
6. Reset the time if needed by following the time programming instructions in this user guide.

Bypass Valve Operation - optional accessory (purchased separately)

Normal Operation

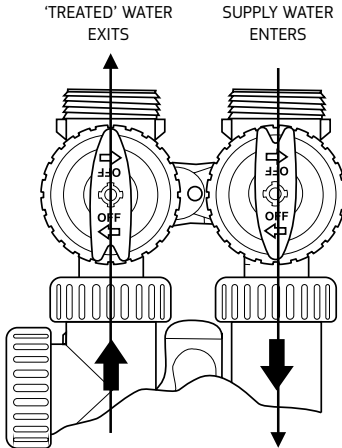

Bypass Operation

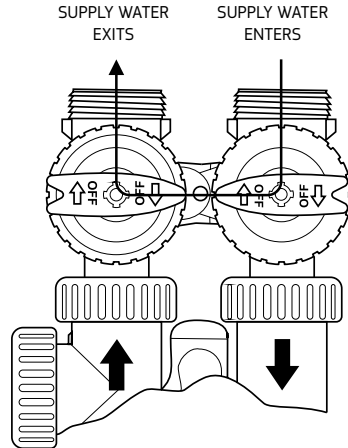

Diagnostic Mode

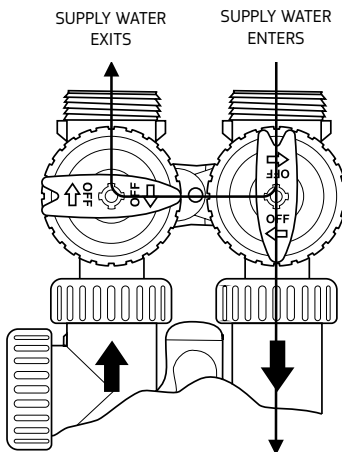

Shut Off Mode

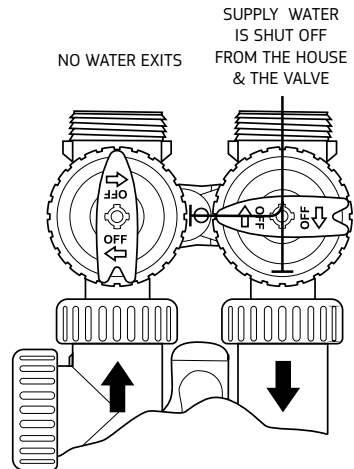

Troubleshooting Guide

<p>'Dry' Reset Procedure</p> <p>From time to time, the valve may display an error code for various reasons. The first troubleshooting step is to perform a 'dry' reset.</p>	<p>Remove the faceplate, opening the tabs on either side of the valve. This will expose the Power Circuit board with a number of wires connected.</p> <p>On the bottom right hand corner is a 4 pin adaptor labelled '12VAC PWR', disconnect the adaptor and reconnect after 5 seconds. The valve will then whir twice, and should return to the normal screen.</p> <p>If the error message is still present, refer to the troubleshooting guide.</p>
--	---

PROBLEM	POSSIBLE CAUSE	SOLUTION
No display/blank screen on valve.	A. Transformer not connected.	A. Connect transformer.
	B. No power at outlet/source.	B. Use working outlet/repair outlet.
	C. Switched outlet/improper voltage.	C. Use uninterrupted outlet/ensure source is delivering proper voltage.
	D. Dead battery.	D. Replace battery (CR2032).
	E. Defective transformer.	E. Replace transformer.
	F. Defective PC Board.	F. Replace PC Board.
Valve does not display correct time of day.	A. Power outage(s).	A. Reset time of day, replace battery (CR2032).
	B. Time of day set incorrectly.	B. Reset to correct time of day.
	C. Switched outlet.	C. Use uninterrupted outlet.
	D. Tripped breaker switch.	D. Reset breaker switch.
	E. Defective PC Board.	E. Replace PC Board.
Valve regenerates at wrong time of day.	A. Power outage(s).	A. Reset time of day, replace battery (CR2032).
	B. Time of day set incorrectly.	B. Reset to correct time of day.
	C. Time of regeneration set incorrectly.	C. Reset regeneration time.
Time of day flashes on and off.	A. Power outage(s).	A. Reset time of day, replace battery (CR2032) and then perform a 'dry' reset.
Valve does not regenerate when performing a manual regeneration.	A. No power to valve.	A. Refer to 'No display/blank screen on valve'.
	B. Broken drive gear or drive cap assembly.	B. Replace drive gear or drive cap assembly.
	C. Broken piston rod.	C. Replace piston rod.
Valve does not regenerate automatically, but does when performing a manual regeneration.	A. Bypass valve in bypass position/faulty.	A. Turn bypass to normal operation/replace bypass.
	B. Defective PC Board.	B. Replace PC Board.

Troubleshooting Guide

PROBLEM	POSSIBLE CAUSE	SOLUTION
Untreated water delivered to service.	A. Bypass valve is in bypass operation/faulty.	A. Turn bypass to normal operation/replace bypass.
	B. Media is exhausted due to high water usage.	B. Check program settings or diagnostics for abnormal water usage.
	C. Fouled media bed.	C. Clean/replace media.
	D. Water quality fluctuation.	D. Test water and contact Puretec for assistance.
	E. No regenerant or low level of regenerant.	E. Refill regenerant tank.
	F. Valve fails to draw regenerant.	F. Refer to 'Valve fails to draw in regenerant'.
	G. Insufficient regenerant level in regenerant tank.	G. Contact Puretec for assistance.
	H. Leak from seal/spacer stack assembly.	H. Clean/replace spacer stack assembly.
Control valve uses too much regenerant.	A. Incorrect refill setting.	A. Contact Puretec for assistance.
	B. Incorrect program setting.	B. Contact Puretec for assistance.
	C. Valve regenerating frequently.	C. Check for leaking fixtures or system undersized.
Regenerant being delivered to service.	A. Low water pressure.	A. Check incoming water pressure – water pressure must remain at minimum of 25 psi.
	B. Incorrect injector size.	B. Replace injector with correct size for application.
	C. Restricted/kinked drain line.	C. Check drain line for restrictions or debris, or unkink drain line.
Excessive water in regenerant tank.	A. Incorrect program settings.	A. Contact Puretec for assistance.
	B. Plugged injector.	B. Clean/replace injector.
	C. Loose/damaged drive cap assembly.	C. Tighten/replace drive cap assembly.
	D. Leak from seal/spacer stack assembly.	D. Clean/replace spacer stack assembly.
	E. Restricted/kinked drain line.	E. Check drain line for restrictions or debris, or unkink drain line.
	F. Plugged backwash flow controller.	F. Clean/replace backwash flow controller.
	G. Plugged refill flow controller.	G. Clean/replace refill flow controller.

PROBLEM	POSSIBLE CAUSE	SOLUTION
Valve fails to draw in regenerant.	A. Plugged injector.	A. Clean/replace injector.
	B. Regenerant piston failure.	B. Clean/replace regenerant piston.
	C. Leak in regenerant line.	C. Inspect regenerant line for air leak.
	D. Restricted/kinked drain line.	D. Check drain line for restrictions or debris, or unkink drain line.
	E. Drain line too long or too high.	E. Shorten length and or height.
	F. Low water pressure.	F. Check incoming water pressure – water pressure must remain at minimum of 25 psi.
Water running to drain.	A. Power outage during regeneration.	A. Upon power being restored control will finish the remaining regeneration time. Reset time of day, replace battery (CR2032).
	B. Foreign material present in valve.	B. Remove drive cap, piston and spacer assemblies. Clean and relubricate components, assemble the valve and run a manual backwash.
	C. Leak from seal/spacer stack assembly.	C. Clean/replace spacer stack assembly.
	D. Piston assembly failure.	D. Clean/replace piston assembly.
	E. Loose/damaged drive cap assembly.	E. Tighten/replace drive cap assembly.
Error Code - 1001 Control unable to sense motor movement.	A. Motor not inserted fully into engage position, motor wires broken or disconnected.	A. Disconnect power, make sure the motor is fully engaged, check for broken wires, make sure two pin connector is connected to the two pin connection on the PC Board labelled MOTOR. Connect power and perform a 'dry' reset.
	B. PC Board not correctly installed.	B. Ensure PC Board is correctly clipped into drive bracket and perform a 'dry' reset.
	C. Board unable to read middle reduction gear.	C. Check foil on reduction gear; clean any foreign material on the foil.
	D. Missing/damaged reduction gears.	D. Replace missing gears.
	E. Defective PC Board.	E. Replace PC Board.
Error Code - 1002 Control valve motor ran too short and was unable to find the next cycle position and stalled.	A. Foreign material lodged in valve.	A. Clean/replace piston/spacer stack assembly. Perform a 'dry' reset.
	B. Mechanical binding.	B. Check piston, spacer stack assembly, drive bracket and main drive gear interface. Perform a 'dry' reset.
	C. Main drive gear too tight.	C. Loosen main drive gear. Perform a 'dry' reset.
	D. Incorrect voltage being delivered to valve.	D. Check voltage of power source. Perform a 'dry' reset.
	E. Incorrect programming.	E. Contact Puretec for assistance.

PROBLEM	POSSIBLE CAUSE	SOLUTION
Error Code - 1003 Control valve motor ran too long and was unable to find the next cycle position.	A. Motor failure during regeneration.	A. Check motor connections. Perform a 'dry' reset.
	B. Foreign material lodged in valve.	B. Clean/replace piston/spacer stack assembly. Perform a 'dry' reset.
	C. Drive bracket not correctly installed.	C. Snap drive bracket in correctly. Perform a 'dry' reset.
Error Code - 1004 Control valve motor ran too long and timed out trying to reach home position.	A. Drive bracket not correctly installed.	A. Snap drive bracket in correctly. Perform a 'dry' reset.

Warranty

Any claim under this warranty must be made within 6 years of the date of purchase of the product. This product is warranted to be free of defect of material and workmanship for 6 years from date of purchase. 6 year warranty is 1 year parts and labour, plus 5 years parts only. Excludes consumables. Puretec is renowned for its quality and after-sales support so if you have any issues please call 1300 140 140 (AU) or 0800 130 140 (NZ). To make a warranty claim, contact us directly or the place of original purchase. All costs relating to a warranty claim must be approved by Puretec prior to any work being carried out.

Puretec will pay your reasonable, direct expenses of claiming under this warranty. You may submit details and proof of your expense claim to place of purchase for consideration.

The warranty only applies if the product was used and/or installed in accordance with the user guide and/or installation instructions. This warranty is given in lieu of all other express or implied warranties and manufacturer shall in no circumstance be held liable for damages consequential or otherwise or delays caused or faulty manufacturing except as excluded by law.

Applicable to all above, is that the warranties need to be approved by Puretec to ensure product was not incorrectly used, installed or claimed. False and incorrect claims will be pursued at Puretec's discretion, including chargeable inspection and labour costs incurred.

All installation and service work should be completed by qualified tradespeople. Faulty operation due to unqualified persons will result in voided warranty coverage.

Warranty/Australia

This warranty is given by Puretec Pty Ltd, ABN 44 164 806 688, 37-43 Brodie Road, Lonsdale SA 5160, telephone no. 1300 140 140 and email at sales@puretec.com.au.

This warranty is provided in addition to other rights and remedies you have under law: Our goods come with guarantees which cannot be excluded under the Australian Consumer Law. You are entitled to replacement or refund for a major failure and to compensation for other reasonably foreseeable loss or damage. You are also entitled to have the goods repaired or replaced if the goods fail to be of acceptable quality and the failure does not amount to a major failure.

Warranty/New Zealand

This warranty is given by Puretec NZ LP, Reg. No 50081773, PO Box 13116, Hillcrest, Hamilton 3251 NZ, telephone no. 0800 130 140 and email at sales@puretec.co.nz.

This warranty is provided in addition to other rights and remedies you have under law: Our goods come with guarantees which cannot be excluded under the Consumer Guarantees Act. You are entitled to replacement or refund for a major failure and to compensation for other reasonably foreseeable loss or damage. You are also entitled to have the goods repaired or replaced if the goods fail to be of acceptable quality and the failure does not amount to a major failure.

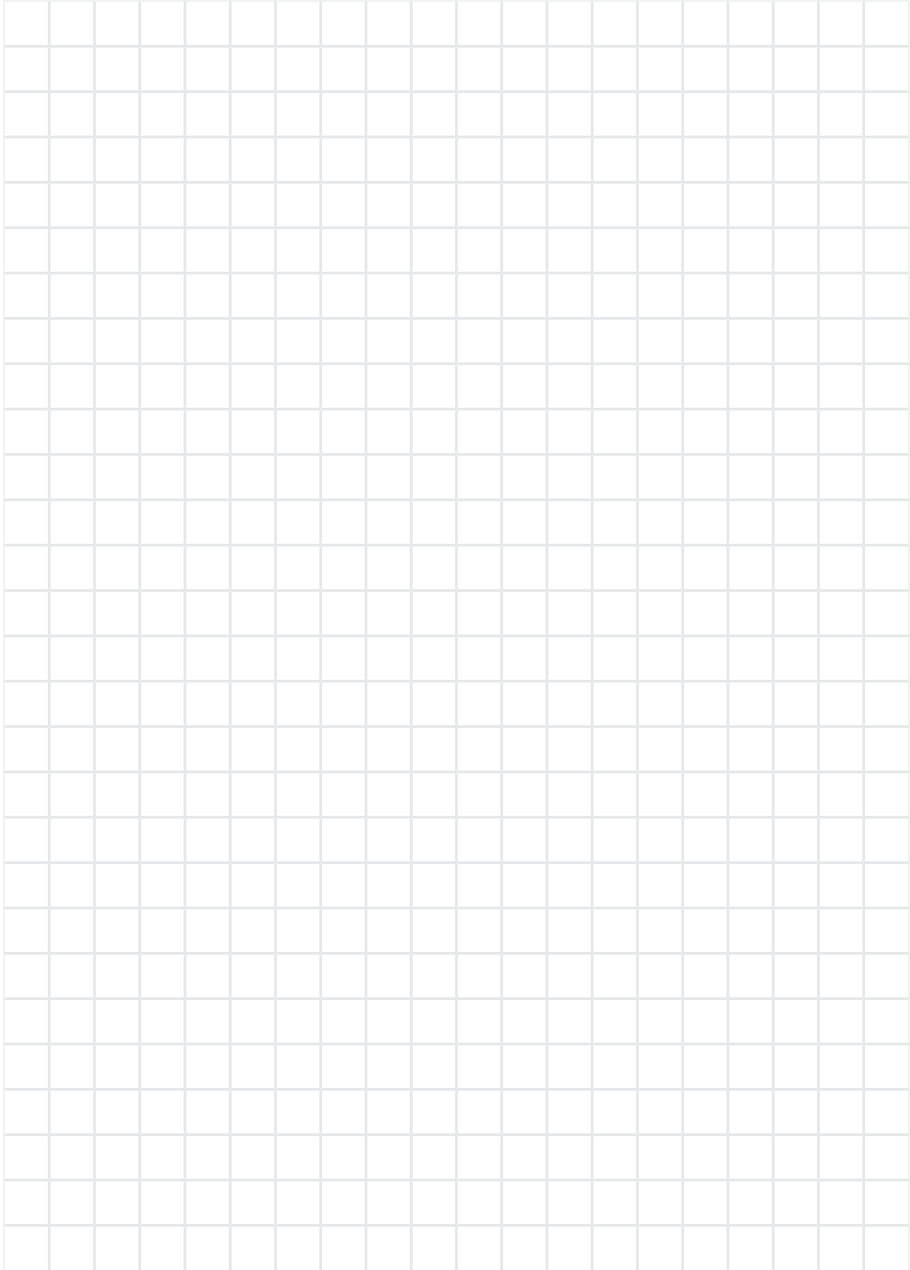

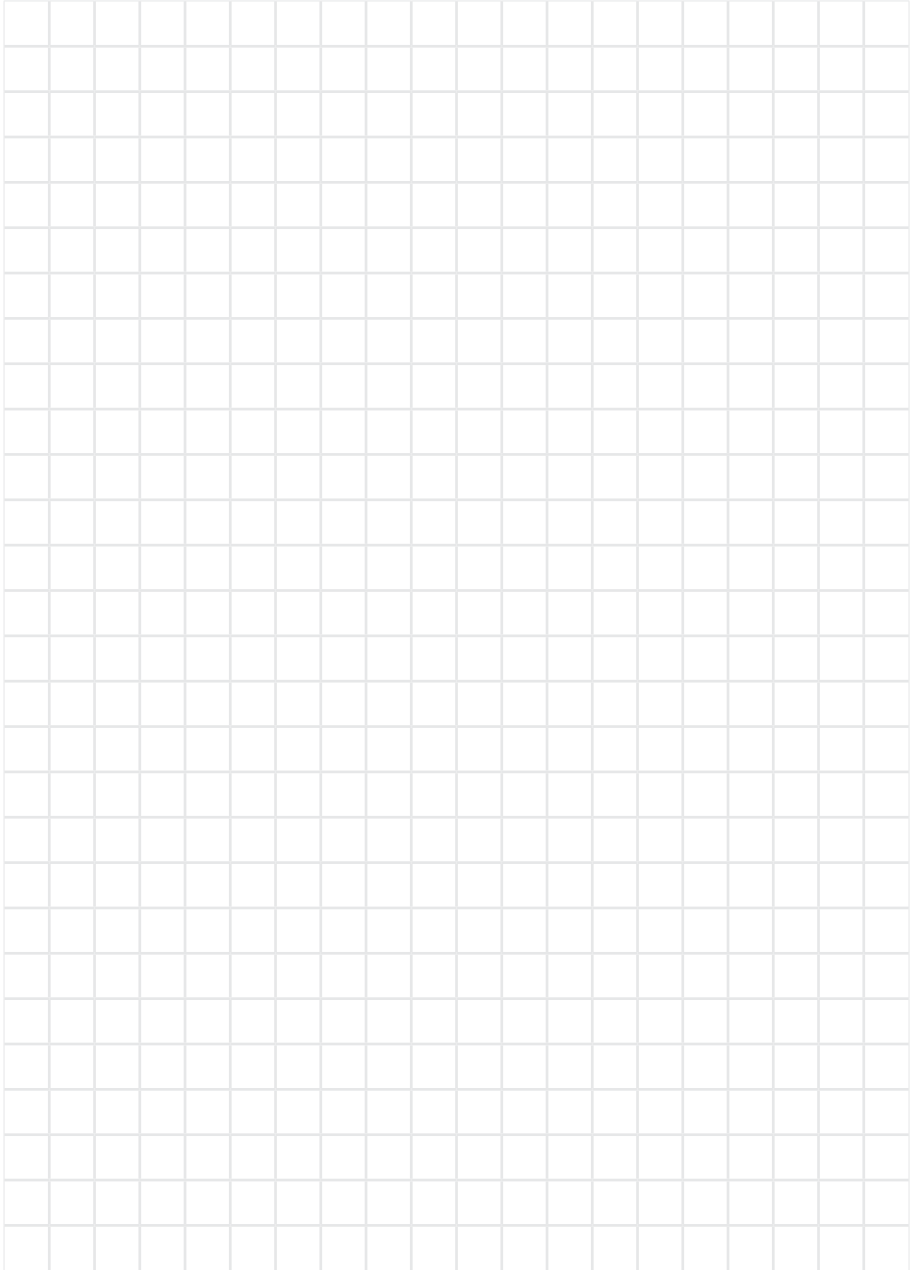



AUSTRALIA

P 1300 140 140

E sales@puretec.com.au

W puretec.com.au

NEW ZEALAND

P 0800 130 140

E sales@puretec.co.nz

W puretec.co.nz