

# Z1-T6

## Quick Twist Undersink Filter System with Tripla™ 3-Way Mixer Tap

MAINS WATER

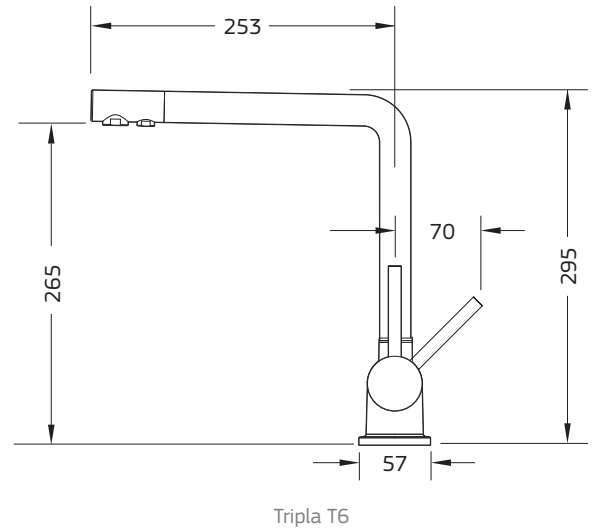
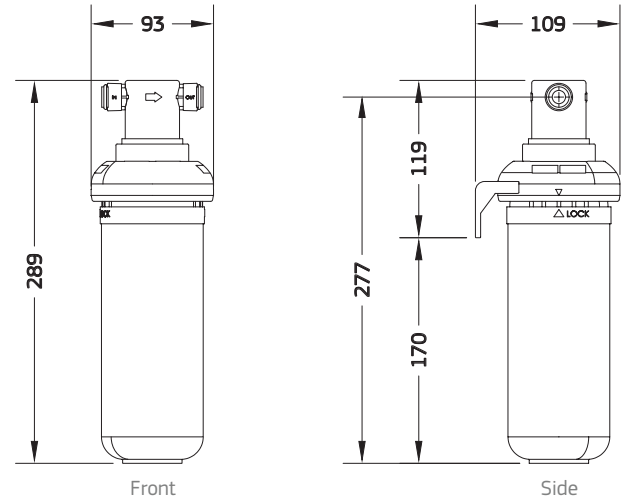

Note: All dimensions are in mm.

### Parts Included

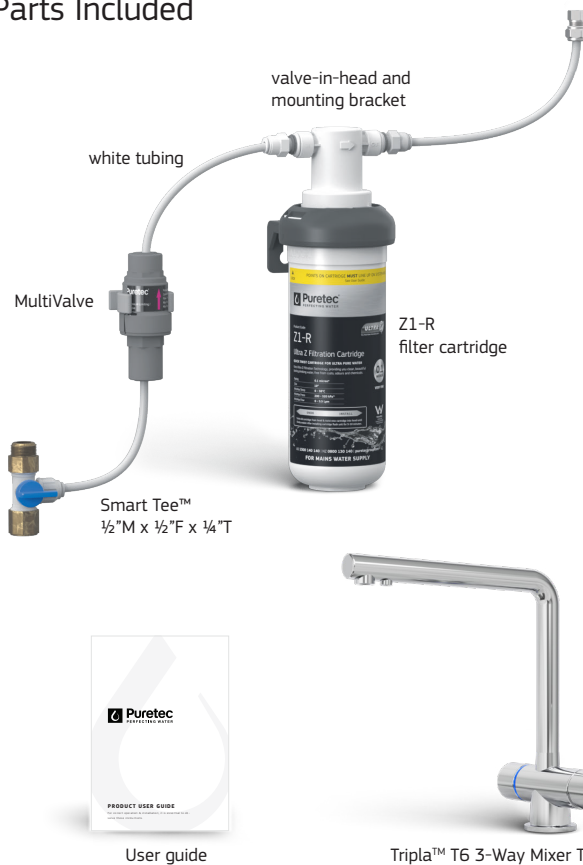

### Specifications

Ordering Code	Temp °C	Pressure** (kPa)	Flow (Lpm)	Micron Rating*	Connection	Cartridge Size	Capacity*** (L)
Z1-T6	0-38	172-520	5.5	0.1	1/2" BSP x 1/4" Tube	10"	30,000
Tripla™ T6	0-60	50-500	5	-	1/2" and 1/4" braided hose		

Wels Rating = 5 Stars. Replacement cartridge code: Z1-R. Required tap hole: 33mm.

Designed to filter mains and town water supply. On high pressure areas where the pressure exceeds the recommended working pressure as indicated, pressure limiting valves must be installed or warranty is voided.

#### Warranty:

Tripla warranty<sup>^</sup> is 1 year parts and labour, plus 5 years parts only. Puretec Z1 Filter Systems warranty<sup>^</sup> is 1 year parts and labour, plus 9 years parts only. Excludes cartridges. Use only genuine Puretec replacement cartridge.



Warning: Please visit [www.puretec.com.au/instructions](http://www.puretec.com.au/instructions) to observe essential manufacturer's instructions before use. Note: No claims can be made based on the specifications and images in this document. The design, technology, colours, features and prices are subject to change. This document and all its contents are copyright protected. All rights are reserved, particularly alteration, translation and reproduction using electronic systems. This spec sheet has been designed to help make product selection easy. However due to the complex nature of water chemistry, we strongly encourage confirming any product selection with one of our team. We may need to perform a water analysis test to confirm contaminants in water. Caution: Do not use with microbiologically unsafe water or water of unknown quality without adequate disinfection before or after the system. Warranty: <sup>^</sup>Warranties in this document cover parts for the period stated and include cover for parts and labour for the first year where applicable, subject to approval. Excludes consumables. Our Water Filtration Specialists can provide you with advice to suit your needs. <sup>\*\*</sup>Where line pressure exceeds 520kPa, an approved pressure limiting device must be installed to comply with Australian & New Zealand Plumbing Standards. (Ref. AS 35001:2021, Clause 3.3.4). Maximum flow depends on cartridges, vessel, pressure, impurities etc. <sup>\*\*\*</sup>Capacity is based on inlet chlorine @2ppm ±10%.